



Modular Industrial Ups Battery Backup Three Phase Uninterruptible Power Supply

Our Product Introduction

for more products please visit us on power-cabinets.com

Basic Information

- Place of Origin: CHINA
- Brand Name: SZDXZH
- Model Number: H10KL
- Minimum Order Quantity: 1 pcs
- Packaging Details: Woodcase/ Paper box
- Delivery Time: 15-25 days
- Payment Terms: T/T
- Supply Ability: 10000pcs/month



Product Specification

- Product Name: Modular UPS/Computer Room UPS
- Country Of Origin: China
- Efficiency (Commercial Power Mode): 0.89
- Intelligent Battery Management System: Yes
- Industrial Voltage Regulator: Yes
- Product Packaging: High Frequency UPS Unit, Power Cord, User Manual, Warranty Card
- Efficiency: 0.89
- Voltage Stability (steady State): $\leq \pm 1\%$ Typical Value (balanced Load) $\sim \leq \pm 2\%$ Typical Value (Unbalanced Load)

Product Description

Manufactured Industrial UPS Power Supply with Intelligent Battery Management System

Product Description:

This power supply unit can accommodate 3 to 10 installable modules, making it capable of handling multiple devices and equipment simultaneously. It is rated at 3*380VAC/400VAC/415VAC(3PH+N), making it suitable for a wide range of industrial applications. The Industrial UPS Power Supply boasts an impressive efficiency rating of 0.89 in commercial power mode, ensuring that your devices and equipment receive consistent, stable power supply. With its high frequency UPS unit, power cord, user manual, and warranty card, this product is packaged to ensure ease of use and maximum customer satisfaction.

Whether you need a reliable power backup for your manufacturing plant, data center, or any other industrial application, the Industrial UPS Power Supply is the perfect solution. Invest in this product today and enjoy uninterrupted power supply for your critical equipment and machines.

Features:

Product Name: Modular UPS/Computer Room UPS

Country Of Origin: China

True Online Double Conversion: 0ms

Support And Services:

Installation And Commissioning

Maintenance And Repair

Remote Monitoring And Management

On-site Technical Support

Training And Education

Rated voltage: 3*380VAC/400VAC/415VAC(3PH+N)

Our industrial ups power backup product provides reliable ups electrical supply with a true online double conversion of 0ms. Made in China, this industrial ups power supply supports installation and commissioning, maintenance and repair, remote monitoring and management, on-site technical support, and training and education. With a rated voltage of 3*380VAC/400VAC/415VAC(3PH+N), our industrial ups power supply is the perfect solution for your power backup needs.

Technical Parameters:

Number of installable modules	3-10
Country Of Origin	China
Rated voltage	3*380VAC/400VAC/415VAC(3PH+N)
Battery Voltage	24V
Product Category	Industrial UPS Power Supply
Efficiency	0.89
Efficiency (Commercial Power Mode)	0.89
True Online Double Conversion	0ms
Voltage stability (steady state)	$\leq \pm 1\%$ Typical value (balanced load) $\sim \leq \pm 2\%$ Typical Value (Unbalanced Load)
Applications	Manufacturing plants, Warehouse and distribution centers, Hospitals and healthcare facilities, Data centers and server rooms, Financial institutions, Telecommunications centers

This Industrial UPS Power Supply is the perfect ups power system for industrial applications requiring reliable power backup. With a battery voltage of 24V, it is designed to provide uninterrupted power supply during power outages. Its efficiency of 0.89 and true online double conversion of 0ms ensures that your equipment stays powered and protected. Its voltage stability (steady state) is $\leq \pm 1\%$ Typical value (balanced load) $\sim \leq \pm 2\%$ Typical Value (Unbalanced Load), making it an ideal choice for manufacturing plants, warehouse and distribution centers, hospitals and healthcare facilities, data centers and server rooms, financial institutions, and telecommunications centers.

Applications:

SZDXZH H10KL is an industrial UPS power supply that provides reliable backup power for industrial applications. It is designed to protect critical equipment from power outages, voltage fluctuations, and other power-related issues. The H10KL model is manufactured in China and has a minimum order quantity of 1. The price of this product is \$626.4, and the supply ability is negotiable. The packaging details

include carton packaging, and the payment terms are T/T. The delivery time is also negotiable.

The SZDXZH H10KL is an industrial UPS power backup that provides voltage stability (steady state) of $\leq \pm 1\%$ typical value (balanced load) to $\leq \pm 2\%$ typical value (unbalanced load). It also has an efficiency of 0.89 in commercial power mode. This industrial UPS power supply is suitable for various industrial applications, including manufacturing, automation, and medical equipment.

The H10KL model of the SZDXZH industrial UPS power supply also has an intelligent battery management system that helps to extend the battery life and improve battery performance. It also ensures that the battery is always ready to provide backup power when needed. Installation and commissioning, maintenance and repair, remote monitoring and management, on-site technical support, and training and education are some of the support and services offered by SZDXZH for their industrial UPS power supply product. This ensures that customers can get the most out of their industrial UPS power supply.

The SZDXZH H10KL industrial UPS power supply is an excellent choice for anyone looking for a reliable and efficient UPS power supply for their industrial applications. It is also suitable for use as a UPS power supply for computers and other critical equipment that require stable and reliable power backup.

Support and Services:

The Industrial UPS Power Supply product is equipped with advanced technology to provide reliable and efficient power backup in industrial settings. Our team of technical experts is available round the clock to provide support and services for any issues that may arise with the product. Our services include:

Installation support

Product training

Remote monitoring and diagnostics

On-site repairs and maintenance

Replacement parts and accessories

We are committed to ensuring that our customers receive the highest level of support and satisfaction with their Industrial UPS Power Supply product.

Packing and Shipping:

Product Packaging:

The Industrial UPS Power Supply product will be packed securely to ensure safe transportation and delivery. Each unit will be placed in a sturdy cardboard box with ample padding to protect it from any potential damage during shipping. The product will be sealed with tamper-evident tape to ensure that it arrives at the customer's location exactly as it left the factory. The packaging will also include a user manual and any necessary installation hardware, as well as a warranty card.

Shipping:

Our company uses reliable and reputable shipping carriers to ensure that your package arrives on time and in perfect condition. We offer both domestic and international shipping options, and customers can choose from standard or expedited shipping methods. Once the product has been shipped, the customer will receive a tracking number that can be used to monitor the progress of the shipment. We take pride in our customer service and will do everything we can to ensure that your Industrial UPS Power Supply product is delivered to you in a timely and efficient manner.

FAQ:

Q1. What is the brand name of the Industrial UPS Power Supply?

A1. The brand name of the Industrial UPS Power Supply is SZDXZH.

Q2. What is the model number of the Industrial UPS Power Supply?

A2. The model number of the Industrial UPS Power Supply is H10KL.

Q3. What is the minimum order quantity for the Industrial UPS Power Supply?

A3. The minimum order quantity for the Industrial UPS Power Supply is 1.

Q4. What is the price of the Industrial UPS Power Supply?

A4. The price of the Industrial UPS Power Supply is \$626.4.

Q5. What are the payment terms for the Industrial UPS Power Supply?

A5. The payment terms for the Industrial UPS Power Supply are T/T.

Q6. What is the supply ability of the Industrial UPS Power Supply?

A6. The supply ability of the Industrial UPS Power Supply is negotiable.

Q7. What are the packaging details for the Industrial UPS Power Supply?

A7. The packaging details for the Industrial UPS Power Supply are carton packaging.

Q8. What is the delivery time for the Industrial UPS Power Supply?

A8. The delivery time for the Industrial UPS Power Supply is negotiable.

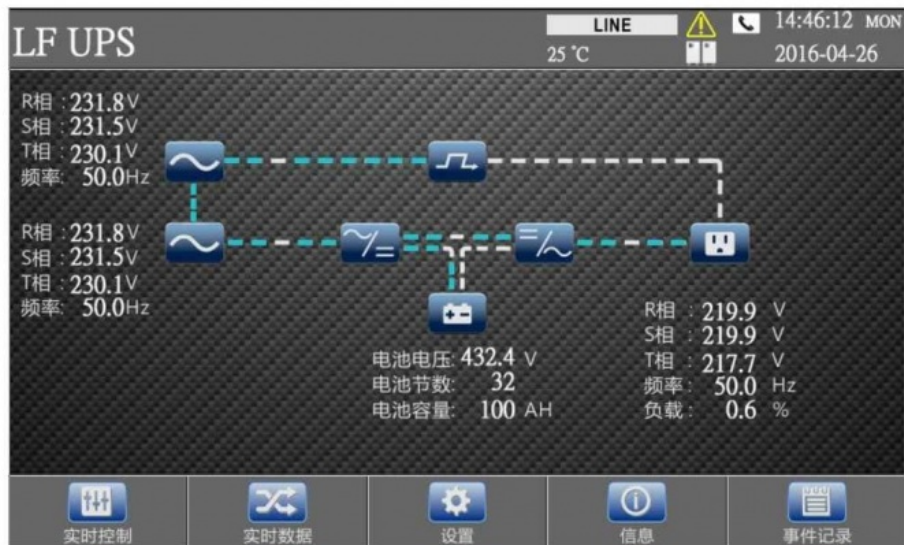
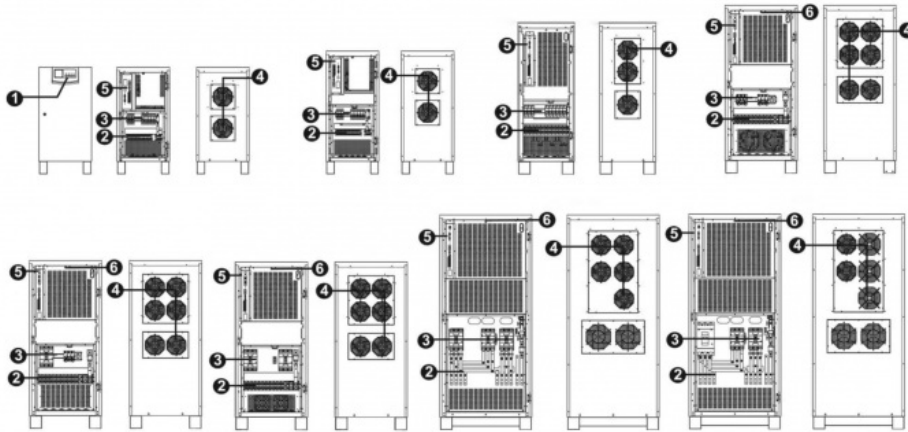
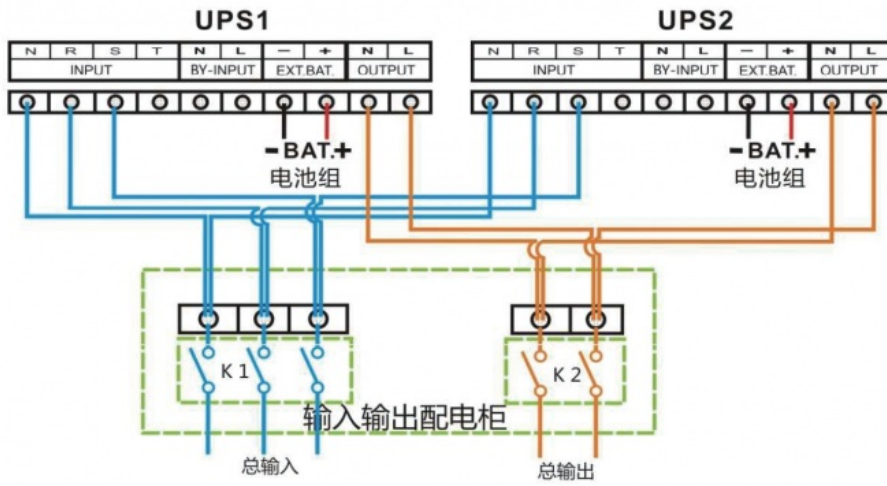

parameter	describe
Input voltage/frequency	Exchange input voltage and frequency
Input voltage/frequency	Exchange input voltage and frequency
Load%	Communication output load percentage
Bypass voltage/frequency	Bypass input voltage and frequency
battery voltage	Current battery voltage value
Number of battery cells	Current number of battery cells
Battery capacity	Current battery pack capacity
real-time control	Provide system control functions
Real-time data	Provide real-time operational data for UPS
Setting	Can modify the operating parameters of the system and its functions
Information	Display current alarm and fault information
Event record	Record warning and fault information
mode	Display the operating mode of the machine in icon form
temperature	Temperature parameters of key components inside the box

01

Stable and reliable

ONLINE DOUBLE CONVERSION TECHNOLOGY COMPLETELY ELIMINATES THE IMPACT OF POWER FAILURES AND EFFECTIVELY PROTECTS THE LOAD FROM UNINTERRUPTED OPERATION



03

Green and Energy Saving

REDUCE ENERGY LOSS, EFFICIENCY UP TO 90%, ULTRA-SMALL SIZE, SIGNIFICANTLY SAVES SPACE

COMPARISON WITH OTHER UPS SYSTEMS

90%



02

Ultra-wide voltage

ULTRA-WIDE VOLTAGE INPUT RANGE, EFFECTIVELY REDUCING THE NUMBER OF BATTERY CHARGES AND EXTENDING

04

Convenient and easy to use

EASY TO OPERATE, LCD DISPLAY, FRIENDLY HUMAN-MACHINE INTERFACE, STANDARD MACHINE











Shenzhen Daxin Intelligent
Equipment Technology Co., Ltd

Shenzhen Daxin Intelligent Equipment Technology Co., Ltd



+86 15817363697



lubenzhi@szdxzh.com



power-cabinets.com

Green Base Industrial Park, Longtian Street, Pingshan District, Shenzhen