



24V Industrial UPS Power Supply For Warehouse And Distribution Centers

Basic Information

- Place of Origin: CHINA
- Brand Name: SZDXZH
- Model Number: H10KL
- Minimum Order Quantity: 1 pcs
- Packaging Details: Woodcase/ Paper box
- Delivery Time: 15-25 days
- Payment Terms: T/T
- Supply Ability: 10000pcs/month



Product Specification

- Intelligent Battery Management System: Yes
- Cabinet Size (Depth*Width*Height)mm: 1100*514*763, 1100*600*1475, 100*600*2010, 1065*600*2000, 1065*1000*2000
- Net Weight Of The Cabinet(KG): 182, 183.5, 335, 437.5, 625, 549, 620, 331, 419, 516
- Efficiency: Up To 94.5%
- Product Category: Industrial UPS Power Supply
- Product Packaging: High Frequency UPS Unit, Power Cord, User Manual, Warranty Card
- True Online Double Conversion: 0ms
- Highlight: **24V Industrial UPS Power Supply ,
UPS Power Supply For Warehouse .**

Product Description

24V Industrial UPS Power Supply For Warehouse And Distribution Centers Up To 94.5% Efficiency

Product Description:

With a commercial power mode efficiency of 0.89, this UPS is designed to maximize power output while minimizing energy waste. The efficiency of this product is up to 94.5%, making it a reliable and cost-effective choice for any industrial application. This Industrial UPS Power Supply is manufactured in China, a country known for its high-quality electronics and technological advancements. The product is made with top-notch materials and engineered to provide superior performance and durability. The 60 KModular UPS/Computer Room UPS is a true online double conversion product, which means it provides a seamless transition between power sources. With a 0ms response time, this UPS ensures that there is no interruption in power supply, making it the perfect choice for applications that require continuous power. The Industrial Uninterruptible Power Supply is a must-have for any industrial setting that requires reliable power. With its efficiency, reliability, and durability, this product is the perfect choice for anyone looking for a high-quality UPS.

Features:

Product Name: Industrial UPS Power Supply

Country Of Origin: China

Model Number: H10KL

Net weight of the cabinet(KG): 182, 183.5, 335, 437.5, 625, 549, 620, 331, 419, 516

Applications: Manufacturing plants, Warehouse and distribution centers, Hospitals and healthcare facilities, Data centers and server rooms, Financial institutions, Telecommunications centers

Product Category: Industrial UPS Power Supply

Features:

Industrial Uninterruptible Power Supply

Industrial Power Protection Unit

UPS Power Backup System

Technical Parameters:

Attribute	Value
Product Category	Industrial UPS Power Supply
Efficiency	Up to 94.5%
Intelligent Battery Management System	Yes
Factory Standby Power Unit	Yes
Model Number	H10KL
Product Name	60 KModular UPS/Computer Room UPS
Cabinet size (Depth*Width*Height)mm	1100*514*763, 1100*600*1475, 1100*600*2010, 1065*600*2000, 1065*1000*2000
Battery Voltage	24V
Support And Services	Installation And Commissioning, Maintenance And Repair, Remote Monitoring And Management, On-site Technical Support, Training And Education
Battery/charging	±216v(12v*36) Maximum voltage, ±240v(12v*40) Minimum voltage, 2.25V/cell Float charging voltage, 2.25V/cell Maximum charging voltage, YES temperature compensation, 8A for 30kw module/6A for 20kw module Maximum charging current
Electric Power Safety Device	Industrial Power Protection Unit

Industrial Power Control Unit	Yes
-------------------------------	-----

Applications:

This Industrial Power Control Unit is perfect for large-scale power generators and industrial power spectators. Its true online double conversion feature makes it stand out from other power supply products with a response time of 0ms. The battery voltage is 24V, and its name is the 60 KModular UPS/Computer Room UPS. The battery/charging specifications are impressive with a maximum voltage of $\pm 216v$ ($12v \times 36$) and a minimum voltage of $\pm 240v$ ($12v \times 40$). It also has a 2.25V/cell float charging voltage and a maximum charging voltage of 2.25V/cell with temperature compensation. The maximum charging current is 8A for 30kw module/6A for 20kw module. The net weight of the cabinet ranges from 182kg to 620kg, making it a sturdy and reliable power supply product. Its modular design makes it easy to install and maintain, making it a popular choice for industrial and large-scale power control applications.

Support and Services:

Our Industrial UPS Power Supply product comes with comprehensive technical support and services to ensure reliable and efficient operation. Our team of experts can assist with installation, configuration, and troubleshooting to minimize downtime and optimize performance. We also offer regular maintenance and servicing to prolong the lifespan of the product and prevent potential issues. Our support services include remote monitoring, on-site repairs, and replacement parts to ensure maximum uptime and customer satisfaction. Contact us for more information on our technical support and services.

Packing and Shipping:

Product Packaging:

The Industrial UPS Power Supply will be securely packed in a sturdy cardboard box to prevent any damage during transit.

All necessary accessories and cables will be included in the package.

A user manual will also be included to guide the customer through the installation and usage of the product.

Shipping:

The Industrial UPS Power Supply will be shipped via a trusted courier service to ensure timely delivery.

Customers will receive a tracking number to monitor the status of their shipment.

Shipping fees may vary depending on the customer's location and the size of the package.

FAQ:

Q: What is the brand name of this Industrial UPS Power Supply product?

A: The brand name of this product is SZDXZH.

Q: What is the model number of this Industrial UPS Power Supply product?

A: The model number of this product is H10KL.

Q: Where is this Industrial UPS Power Supply product made?

A: This product is made in China.

Q: What is the minimum order quantity for this Industrial UPS Power Supply product?

A: The minimum order quantity for this product is 1.

Q: What is the price of this Industrial UPS Power Supply product?

A: The price of this product is \$626.4.

Q: What are the payment terms for this Industrial UPS Power Supply product?

A: The payment terms for this product are T/T.

Q: What is the packaging for this Industrial UPS Power Supply product?

A: The packaging for this product is carton packaging.

Q: What is the delivery time for this Industrial UPS Power Supply product?

A: The delivery time for this product is negotiable.

Q: What is the supply ability for this Industrial UPS Power Supply product?

A: The supply ability for this product is negotiable.

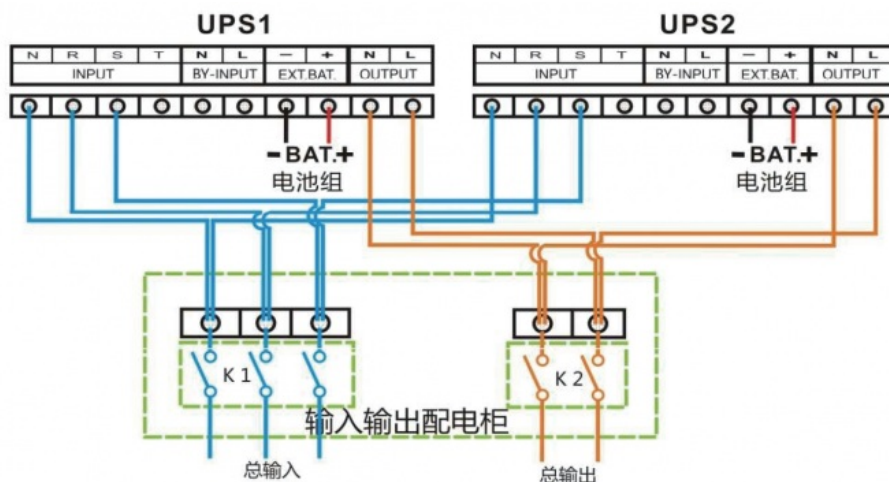

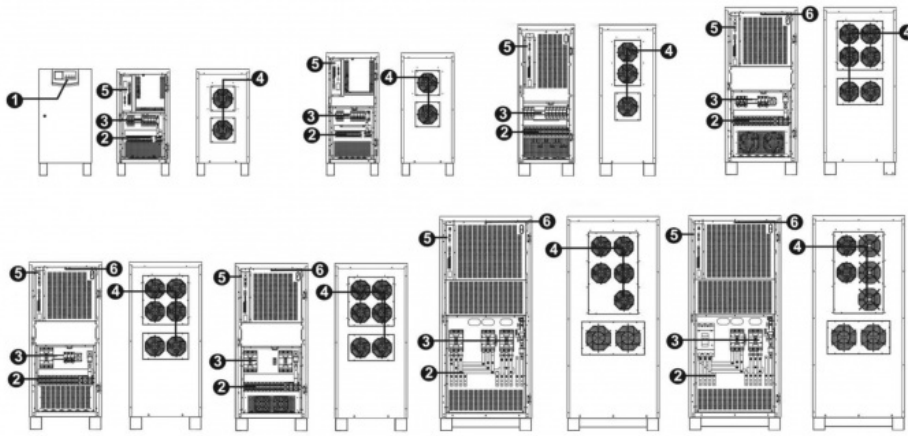

parameter	describe
Input voltage/frequency	Exchange input voltage and frequency
Input voltage/frequency	Exchange input voltage and frequency
Load%	Communication output load percentage
Bypass voltage/frequency	Bypass input voltage and frequency
battery voltage	Current battery voltage value
Number of battery cells	Current number of battery cells
Battery capacity	Current battery pack capacity
real-time control	Provide system control functions
Real-time data	Provide real-time operational data for UPS
Setting	Can modify the operating parameters of the system and its functions
Information	Display current alarm and fault information
Event record	Record warning and fault information
mode	Display the operating mode of the machine in icon form
temperature	Temperature parameters of key components inside the box

01

Stable and reliable

ONLINE DOUBLE CONVERSION TECHNOLOGY COMPLETELY ELIMINATES THE IMPACT OF POWER FAILURES AND EFFECTIVELY PROTECTS THE LOAD FROM UNINTERRUPTED OPERATION

03

Green and Energy Saving

REDUCE ENERGY LOSS, EFFICIENCY UP TO 90%, ULTRA-SMALL SIZE, SIGNIFICANTLY SAVES SPACE

COMPARISON WITH OTHER UPS SYSTEMS

90%

02

Ultra-wide voltage

ULTRA-WIDE VOLTAGE INPUT RANGE, EFFECTIVELY REDUCING THE NUMBER OF BATTERY CHANGES AND EXTENDING

04

Convenient and easy to use

EASY TO OPERATE, LCD DISPLAY, FRIENDLY HUMAN-MACHINE INTERFACE. STANDARD MACHINE









Shenzhen Daxin Intelligent
Equipment Technology Co., Ltd

Shenzhen Daxin Intelligent Equipment Technology Co., Ltd



+86 15817363697



lubenzhi@szdxzh.com



power-cabinets.com

Green Base Industrial Park, Longtian Street, Pingshan District, Shenzhen